

MISS CRYSTAL SPRINGS RODEO QUEEN & JR QUEEN CONTEST

June 26, 2024 - Clear Lake, SD

OFFICIAL HANDBOOK, RULES AND REGULATIONS



Miss Crystal Springs Rodeo and Junior Miss Crystal Springs Rodeo is a young woman who strives to promote the Crystal Springs Rodeo in Clear Lake, SD, the sport of rodeo, and South Dakota’s western heritage. She is a young woman who is a talented horsewoman, acts professionally, displays good sportsmanship, is personable and demonstrates vast knowledge of the sport of rodeo, the Crystal Springs Rodeo, and the western way of life.

If you have any questions, please contact the Crystal Springs Rodeo Queen Contest Director:

Courtnie Uckert 402.740.1674 or smithcourtnie1@gmail.com

YEAR	MISS CRYSTAL SPRINGS RODEO	JR MISS CRYSTAL SPRINGS RODEO
2021	Paige Frensko	
2022	Addyson Wittnebel	
2023	Gracie Hill	
2024	TBD	TBD

Eligibility

1. The Miss Crystal Springs Rodeo offers titles in two separate age groups. Contestants must be within the ages of title they're competing for on the date of the pageant:
Miss Crystal Springs Rodeo: 19 years – 26 years
Jr. Miss Crystal Springs Rodeo: 13 years – 18 years
2. For proof of age you must submit a copy of your driver's license or birth certificate.
3. All titleholders' reign will be from the time of their coronation to the time of coronation of the next queen the following year.
4. Must be a resident of the state of South Dakota or attending a school in South Dakota.
5. If you are not a resident but are attending school in South Dakota, you must present your student ID or college you have been accepted to and will be attending.
6. Commit to abiding by all rules and regulations presented.
7. Must have **sufficient riding and horsemanship skills**.
8. Contestants will be available for the entire performances of the Crystal Springs Rodeo June 26-29, 2024.
9. The contestant may not run for another title during her reign. The only exception will be competing for Miss Rodeo South Dakota or Teen Miss Rodeo South Dakota, respectively.
10. No contestant may have been married or pregnant, have a child, nor become engaged, married, or pregnant during the year of her reign.
11. Submit the required entry fee of **\$50**. Please make checks payable to **Crystal Springs Rodeo, Inc.**, in the memo portion please write "**Queen Application**".
12. Contestants must have executed all consents and/or waivers of liability presented as conditions required prior to competition.
13. Submit the signed and notarized Liability Waiver form.
14. The committee reserves the right to adjust all eligibility and guidelines in this handbook as needed for extenuating circumstances.
15. Email a color head and shoulders photograph (with hat) in a digital format as a JPEG attachment. This photograph will be used for the program and social media.
16. Bring a 8x10 color head and shoulder photo to orientation for the photogenic contest.
17. Each contestant shall provide her own transportation to each function, performance and or event.

Liability

- The **Crystal Springs Rodeo, Inc.** committee and all affiliates are not liable for any personal injuries that may occur during the course of the pageant, rodeo performances or any sponsored events.

Conduct of Contestants

- Contestants must conduct themselves in a professional and ladylike manner and portray high moral standards at all times.
- Unsportsmanlike conduct will not be tolerated. Unsportsmanlike conduct could result in disqualification and affect further eligibility to compete in the Miss Crystal Springs Rodeo Queen contests.
- Should circumstances occur that a contestant is conducting herself in an improper manner, a meeting between the queen coordinator and a director from the Crystal Springs Rodeo, Inc. committee will be held and proper measures will be taken, up to and including dismissal and/or disqualification of the contestant and future contests.

Electronic Device Usage

- Contestants may not possess or use any electronic devices, including but not limited to: cell phones, tablets, laptop computers, smart watches, and any device with internet capabilities.
- These devices may be left with family or friends or turned off and put away during the course of the contest.

Crowns and Banners

- No current title shall be worn by any contestant during the duration of the pageant. This includes crowns, banners and chaps.
- Photos submitted for photogenic judging and the program should not include crowns or banners.

Grievances

- Any grievances must be submitted by the contestant herself to be a valid grievance.
- The contestant must file her grievance with the pageant coordinator immediately after the infraction occurs.
- The pageant coordinator will discuss the grievance with a director from the Crystal Springs Rodeo, Inc. committee.

- All parties involved will be interviewed and the committee will come to a majority decision based on facts. The decision will be made without a doubt that the misconduct by the implicated was intentional or that there was an infraction of a rule.
- At the discretion of the pageant coordinator and director from the Crystal Springs Rodeo, Inc. committee, the implicated may be disqualified and forgo competing in any further Miss Crystal Springs Rodeo contests.

Parents, Relatives and Friends

- Parents, relatives, and friends of contestants are welcome to attend the contestants horsemanship, modeling, speech and rodeo performances.
- If the event requires a ticket for entry, parents, relatives, and friends must purchase their own ticket.
- Parents, relatives, and friends of contestants will be responsible for their own transportation, lodging, and meals during the pageant.
- A judge or another contestant may not be approached by a contestant or any individual with the intent to influence or harass, disqualification of that contestant could result.
- Parents, relatives and friends must show good sportsmanship during and after the pageant or will be asked to leave the event.

Contest Details

- Contestants will be judged in horsemanship, personal interview, public speaking, appearance, personality, a written test and photogenics by a panel of three judges.
- A detailed pageant schedule will be sent out **two weeks** prior to the pageant.
- The order in which each contestant competes will be randomly drawn by the queen coordinator for each event prior to the contest. Contestants will find out the order the day of the pageant.

Judges and Scoring

- Three judges will be selected based on their expertise and knowledge and experience in western horsemanship, professional rodeo, personality, speech and western dress.
- In the event of a tie, the head judge will determine the winner of that event.
- The contest director and a director from the Crystal Springs Rodeo, Inc. committee will tally the scores for each event at the conclusion of the contest.
- At no point will score sheets be available for the contestants, parents or others of the public to see.
- Comment sheets may be available at the judges discretion following the contest.

Awards

- Will be given to the high point contestants in horsemanship, written test, personality, public speaking, appearance and photogenics.
- The Miss Congeniality award will be voted on by the contestants at the end of the competition. This award will not count towards the grand total score. If there is a tie, the contestant with the highest personality score will win the Miss Congeniality award.
- The contestant who receives the highest grand total score for each age group will be crowned Miss Crystal Springs Rodeo Queen, Jr. Miss Crystal Springs Rodeo. The contestant receiving the second highest grand total score will be first runner-up in each age division.
- In the event there is only one contestant in an age group, she must compete in all categories and earn a minimum of 70% of eligible points to win the title.
- Coronation will be held during intermission of Xtreme Bulls on Wednesday, June 26th in the Crystal Springs Rodeo Arena.

Horsemanship

- Balance, position of hands, feet, overall position in the saddle, control of mounting and dismounting.
- Must maintain complete control and do not lose stirrups, reins or hat.
- It is the responsibility of the contestants to make sure their hats stay securely on their heads. Failure to do so will result in point penalties.
- The judges may elect to require the contestants to perform any other horsemanship related tasks they deem relevant.
- Contestants should remember that they will be judged on how they cue the horse, not the horses' ability. Contestants should strive for a smooth pattern.
- Failure to execute the set pattern will not constitute disqualification of the contestant.
- Senior Queen contestant Horses will be sponsored and all tack will be provided.
- The contest coordinator will randomly draw the horse that each Senior contestant will be riding for the first and second go-round of the contest.
- Junior Queen contestants **MUST** provide their own horse for the horsemanship competition.
- Contestants must ride in a western style saddle with split reins. No two-handed riding is permitted.
- Contestants must be wearing a form fitting horsemanship or a western shirt/blouse, pants/jeans, boots, belt, western hat.
- No spurs, chaps, vests or jackets are allowed during the horsemanship competition.
- Each contestant should focus on their ability to utilize the horse that has been drawn for them for each go-round.

- Should an unfair situation occur, at no fault of the contestant, a re-ride will be granted at the sole discretion of the pageant judges.
- Refer to pgs. 11-12 for the horsemanship patterns. One of the two patterns will be selected for the contest; the contestants will be notified at orientation which pattern has been selected.
- First Go-Round
 - Each contestant will ride the required pattern, approach the judges, and dismount.
 - The judges will ask questions pertaining to horse anatomy, diseases, care, rodeo terminology and rules, tack, etc.
 - The contestant will then remount, exit the arena, grab a flag and complete her flag run; no flag boots allowed.
- Second Go-Round
 - Each contestant will be allotted 1 ½ minutes to complete a freestyle pattern.
 - The following 4 elements must be included and may be completed in any order:
 1. Lead change
 2. Back
 3. Stop
 4. Presentation run
 - A warning will be announced when 30 seconds remain and “TIME” will be announced when 1 ½ minutes have elapsed.

Personal Interview

- Each contestant will have a private personal interview with the judges that will be 10-15 minutes in length.
- Questions may include/ not limited to the contestant's application, about herself, horsemanship, general rodeo, equine science, current events and personal opinions.
- The contestant will be judged by her poise, intelligence, conversational ability, authenticity, and content of her answers.
- Each contestant should be dressed in western professional attire such as western dress, skirts, jackets, vests, boots and complete with western hat, belt, accessories.

Modeling

- Each contestant will model an outfit of her choosing and then give her speech.
- This outfit will showcase the contestant's individual style and personality in a modest and appropriate way.
- Contestants should pick outfits that reflect fashionable and tasteful western clothing.
- Dresses or skirt outfits may be worn and should be of a western style.
- Western elegance attire may also be worn by a contestant – this is the rodeo queen version of the evening gown.

- All dresses must have sleeves and sleeves should be longer than a cap sleeve. If the dress or top does not have sleeves, then a jacket with sleeves must be worn.
- The skirt length should not be more than 3 inches above the knee.
- No halter or prom type dresses. No midriff showing. Nothing extremely low cut in the front or the back.
- Each outfit should be completed with western hat, boots, belt and accessories.
- Judges will be looking for proper fit clothing, posture, how the contestant carries herself, awareness of fashionable western dress.
- Each contestant must bring a notecard to orientation describing her entire outfit. This will be read while she is modeling.

Public Speaking

- Each contestant will model then go straight into giving her speech.
- Speeches will be timed by the contest coordinator and should be **1 ½ minutes** in length.
- Deductions may occur if a contestant goes over or under time. Any deductions will be at the judges discretion.
- The contestants will choose between 3 speech topics the day of the contest.
- Each contestant will have 10 minutes to prepare and deliver their speech. Contestants will be given pen and/or pencil and paper to write their speech but will not be allowed to use any materials while giving their speech.
- Speeches will be judged on content, presence during the delivery, enunciation, projection to the audience, eye contact, knowledge, poise, confidence, creativity in developing speech and personality.
- Each contestant will be asked 2 impromptu questions following her speech.

Written Test

- A 25 point written test will be given with questions consisting of Crystal Springs Rodeo, PRCA and WPRA rules, equine terminology, current events, tack, sponsors, Miss Rodeo America and Miss Rodeo South Dakota.
- Senior and Junior contestants will take the same test.
- Each contestant will be provided with a pen/pencil.
- Absolutely no talking amongst contestants will be allowed during the course of the test. Failure to abide will result in immediate disqualification.
- The highest score will be the winner of this category.

Personality

- Projects intelligence, integrity, high moral standards, maturity and common sense.
- Radiates self-confidence and positivity.
- Approachable, friendly and a genuine interest in other people.

- Ambitious, creative, enthusiastic and charismatic.
- Judges will be looking for contestants to handle each situation that they are involved in with ladylike behavior, grace and style.
- Conversational ability in rodeo and other areas, with special emphasis on grammar and enunciation.
- Personality will be judged throughout the entire pageant.

Appearance

- Personal style and knowledge of western attire.
- Posture, poise and lady-like behavior in every situation.
- Contestants exude self-confidence and carry themselves straight and tall.
- Neatness and cleanliness in every detail, such as clothing, hat, boots, accessories, hair and nails.
- General appearance will be judged throughout every pageant event.

Photogenic

- Judges will score each contestant's 8x10 head and shoulders photograph on overall appearance, expression, attitude, choice of colors, personality, eye contact with the camera, clarity and quality of the photograph to determine the winner.

Expectations

As Miss Crystal Springs Rodeo Queen the following is expected of you:

- Reigning queens shall attend all performances of the Crystal Springs Rodeo June 26-29, 2024, the parade as well as all autograph signings and interviews.
- Attend at least 5 Badlands Circuit rodeos during her reign.
- Portray excellence in sportsmanship, high moral and ethical behavior and reflect careful and humane treatment of animals.
- Conduct oneself in a professional and ladylike manner in public and while on social media platforms and have no involvement in any illegal activity.
- You are an example to young impressionable kids, and as such, you must conduct yourself in an exemplary manner.
- Maintain living or going to school in the state of South Dakota during her entire reign.
- Will be responsible for the care and safekeeping of traveling crown and chaps. At the end of her reign, if the crown or chaps are returned with damages she will be subject to pay for repairs or replacement.
- Senior Queen will be granted access to the Miss Crystal Springs Rodeo Facebook page and regularly post throughout her reign. She may use this platform to promote the Crystal Springs Rodeo, sponsors and events that she is attending throughout the year. She may

also post pictures sent from the Jr. Queen, which is the Jr. Queen's responsibility to write a post and send pictures.

- Must remain unmarried and not pregnant for the duration of her reign.
- As Miss Crystal Springs Rodeo and Jr. Miss Crystal Springs Rodeo, it is her responsibility to supply all her own transportation, housing, equipment and stock throughout her reign.
- Throughout your reign, significant others cannot be a distraction while you are performing your duties. They cannot "hang out" or accompany you to events. This is not acceptable.
- Miss Crystal Springs Rodeo and Jr. Miss Crystal Springs Rodeo must be able to help with the following year's queen contest, June 25, 2025.
- When making appearances in rodeos and other events, you must arrive on time and well dressed in queen fashion. Remember you represent the Crystal Springs Rodeo.
- If for any reason it is determined that the reigning Miss Crystal Springs Rodeo, Jr. Miss Crystal Springs Rodeo, cannot fulfill her duties during any portion of her term the 1st runner up will be eligible to assume the title. Upon such time as the reigning queen is dismissed, or forfeits her title, all scholarship funds, awards, and gifts given in relation to the position must be returned to the Crystal Springs Rodeo Queen Coordinator.
- **Must Abide by all rules set forth by the Crystal Springs Rodeo, Inc. committee.**

HORSEMANSHIP PATTERN #2:

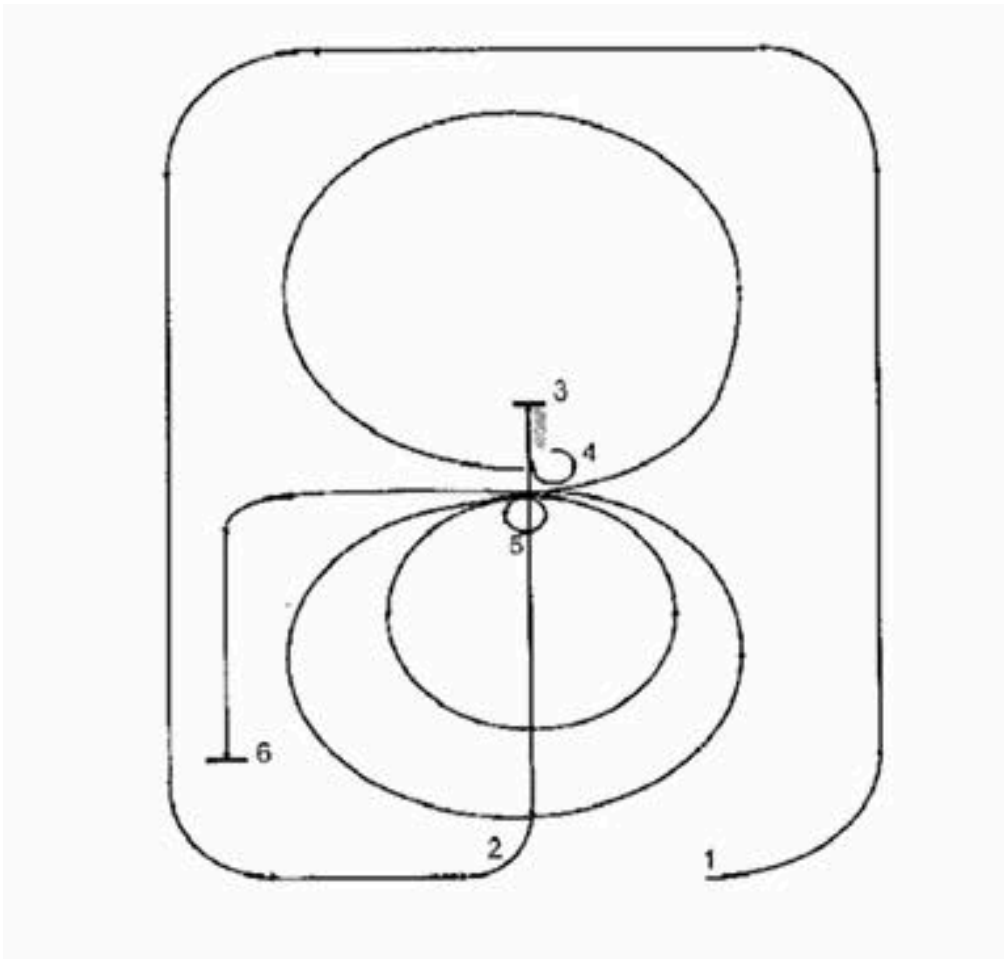

Horsemanship Pattern #2:

1. Circle the arena on the left lead at an extended lope.
2. Guide left and lope down the center of the arena with moderate speed.
3. Pass the center of the arena, stop and back to the center.
4. Execute a $\frac{3}{4}$ turn to the right and lope a circle to the right with moderate speed.
5. Stop in the center, execute a 360 degree turn to the left. Lope a small slow circle to the left followed by a larger faster circle to the left. At the center of the arena, rate back to the slower speed and continue loping on the left lead toward the end of the arena.
6. Stop and pause to show completion of pattern. You should be near the judges at the end of your pattern.
7. Dismount and lead your horse to the judges.
8. Judges will ask you questions.

I, _____, understand that by signing below I hereby certify that I have read the handbook, rules and regulations governing the Miss and Junior Miss Crystal Springs Rodeo Pageant and that I acknowledge and agree to abide by these rules and regulations. I hereby release the Crystal Springs Rodeo, Inc. Committee and Queen Committee from responsibility of injury or loss to persons or property, involving me or persons, relative to my contest appearance, sponsors, commercial and private, or the contest and all officers, directors and member individuals and groups of the contest and Crystal Springs Rodeo, Inc. Committee. I hereby release title, claim, and rights to photographs and/or public relations materials involving me to the contest for use in contest promotion. As a contestant, I will conduct myself in a professional manner and will not demonstrate any unsportsmanlike behavior. I verify that I have read the contest rules, have never been married, am not now nor have I ever been pregnant, or have children. I understand that if I am injured, Crystal Springs Rodeo, Inc. and all affiliates are not liable. I hereby affix my signature attesting my agreement to the above without reserve.

Contestant Printed Name: _____ Date: _____

Contestant Signature: _____ Date: _____

Signature of parent or legal guardian: _____ Date: _____
(if contestant is under 18 years of age)

Applications are due May 31st - application fee \$50

Please mail checks to:
Crystal Springs Rodeo
ATTN: Queen Application
P.O. BOX 47
Clear Lake, SD 57226

Pageant Coordinator
Courtne Uckert 402.740.1674 smithcourtne1@gmail.com

Applications and required documents can be emailed to Courtne; please reach out if you have any questions about the application or pageant.